

M.2 – UPS and Power Management HAT for Raspberry Pi 5 Version Advanced/PPoE

The M.2 **U**ltimate **P**ower Management **S**ystem with RTC, Enhanced **P**eripherals and **I**²C control Interface

Intelligent **M**obile **P**ower **B**ank Ultra - High Current Extended Buck Supply of 5.0A

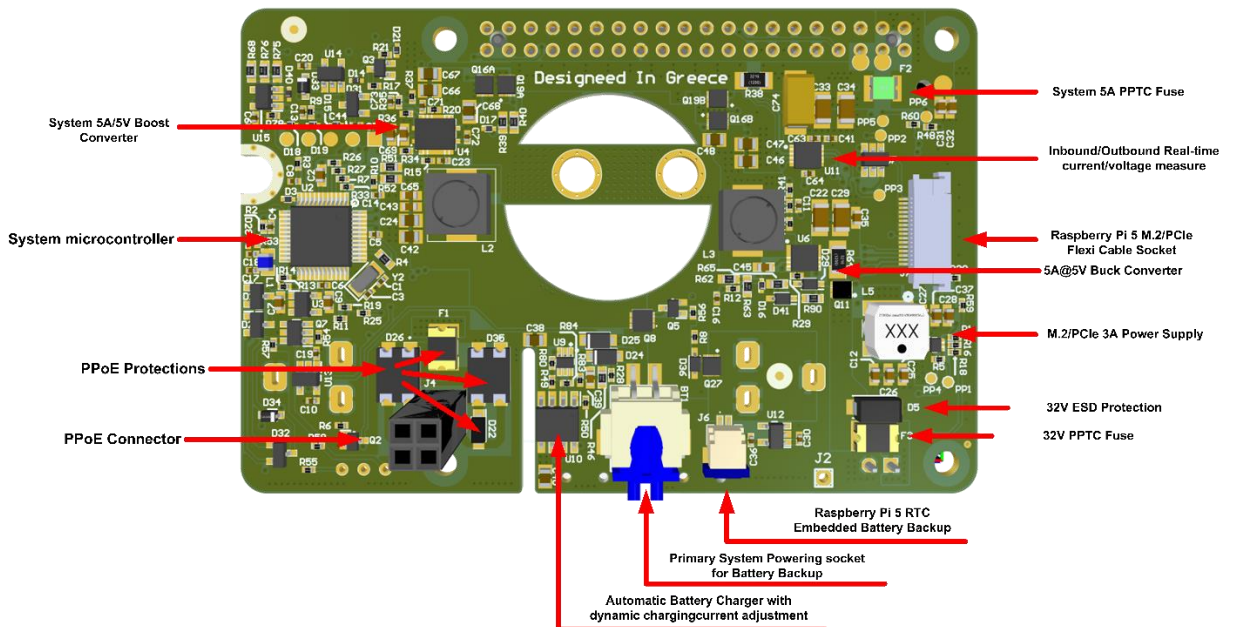
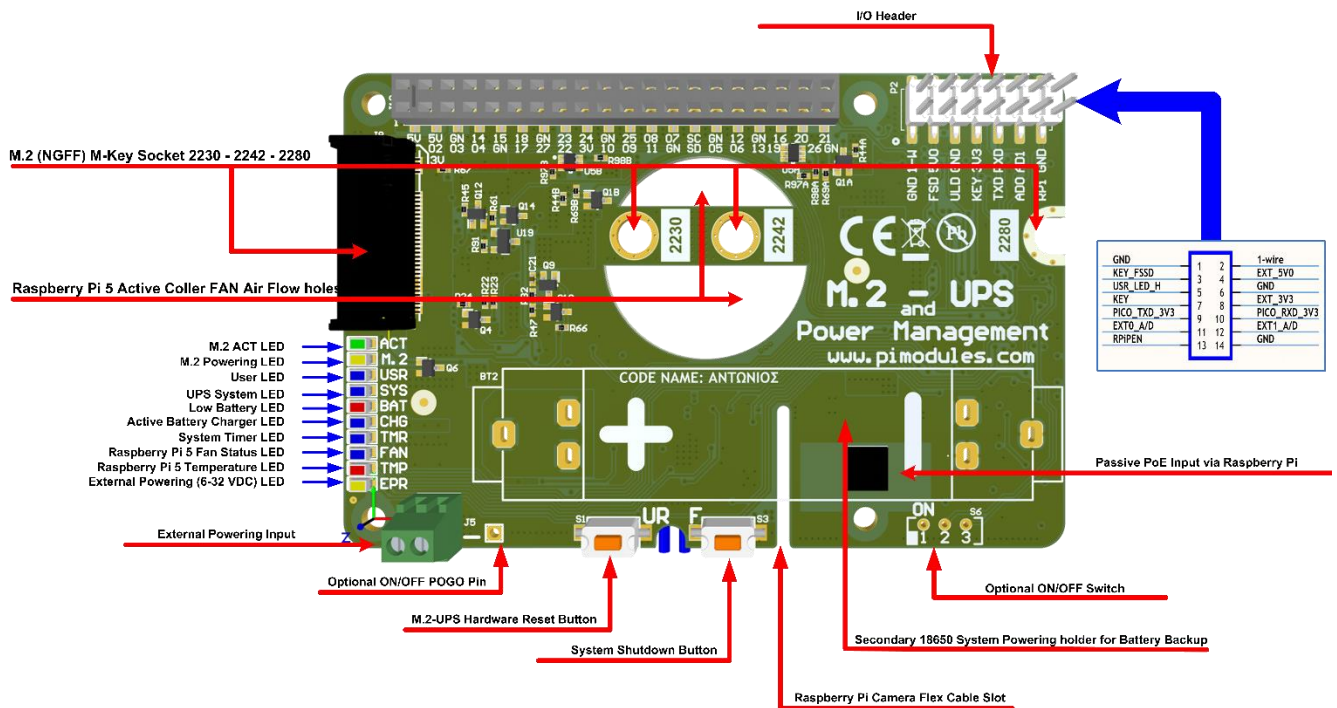

The **M.2 – UPS & Power Management HAT** is an Ultimate Power Management System HAT designed especially for **Raspberry Pi® 5** that open the full functionality of their embedded PCIe **M.2(NGFF)** interface and adds a wealth of innovative powerful and development features to the **Raspberry Pi® 5** microcomputer!

It has been designed especially for the **Raspberry Pi® 5** and considers all enhanced power and cooling requirements of the **Raspberry Pi® 5** models. It has been designed to work with **Official Cooler** exploring their enhanced cooling capabilities for **Raspberry Pi** as also for the added **M.2** devices.

The core functionality of the **M.2 – UPS & Power Management HAT** is to provide an interface for **M.2(NGFF) M-Key (2230, 2242 and 2280)** and at the same time protect and automatically shut-down your **Raspberry Pi® 5** if there is a cable power failure and can be set to automatically monitor and reboot your Pi once cable power has been restored!

However, it is only a small part of plenty and powerful functionalities that are implemented on this small HAT. The new **M.2 – UPS & Power Management HAT** contains two selectable backup power sources that can be used (once at a time). The wide available on the market Battery **18650** Li-Ion or large selection line of **XH-2.5** connector (600 mAh – 10 000 mAh) cover any extended Battery Backup request.

The new **M.2 – UPS & Power Management HAT** is the only one that supplies the **Raspberry Pi® 5 RTC** with battery backup (**J5**) and eliminates the need to use an additional battery for this purpose.

Last but not least is that implemented M.2 interface is equipped with **32786 kHz clock**, similar to the official **Raspberry Pi® 5 M.2 HAT**.

The new **M.2 – UPS & Power Management HAT** does not need any additional powering cable and thanks to the implemented proprietary monitoring algorithm monitors the and current consumption via GPIO and other powering sources.

The new **M.2 – UPS & Power Management HAT** offers an External Powering Input of 5V0 – 32V0 supply that can be easily used with any existing Solar Panel. Due to implemented **Power Tracking** and **Dynamic Charging Algorithm**, adopt the system power needs to the available Solar Power!

The **External Powering** Input and the **GPIO Powering** (via **USB-C**) can be connected at the same time and system decides what Power source will be selected!

In addition to the listed powering sources an extra powering source has been implemented – the **Passive PoE**. Much simpler and much lower cost than the PoE/PoE+. The **M.2 – UPS & Power Management HAT** can be powered through the Ethernet without expensive equipment, just with a simple power injector that costs 2 EURO. This an ideal solution for a low-cost homemade **PoE Systems** based on the **Raspberry Pi 5** and **M.2 – UPS & Power Management HAT**

System Specifications

<p>General</p> <ul style="list-style-type: none"> - Dimensions: 85mm x 56mm - Email broadcasting on events (Cable Power loss/return, Wake-up, User Button, System Status) - Plug and Play - Ultra-light System.d Daemon based on threading - GPIO free (all GPIOs are available for user application) interaction with Raspberry Pi® via I²C - Enhanced System Monitoring and Programming API - Labeled J8 Raspberry Pi® GPIO Pins for Easy Plug & Play of experimental cables - Standard THT 40 Pin connector (not soldered) - Remote bootloader for Live Firmware Update on remote locations - Local bootloader for Live Firmware Update 	<p>Powering Options</p> <ul style="list-style-type: none"> - Protected (ESD, over current (PPTC fuse), 5A Supply @5V) - 2 selectable power back-up sources: 18650 Battery or XH-2P socket cable Battery - Enhanced Line Interactive UPS functionality (25us response time) powered via Raspberry Pi® 5 5V GPIO - Enhanced On-Line UPS functionality when powered via EPR 5V0-32V0 or PPoE - Automatic Advanced Proprietary Power Spikes Tracking Algorithm - Additional/Alternative to Raspberry Pi® 5 File Safe Shutdown and Start-up Functionality on a Single Button - Continuously 5.0A@5.25V supply on battery power backup - Intelligent Mobile Power Bank functionality with safe shutdown/start-up, with Internal or External Slide Switch and RTC - Backup Supply Source (via additional Cable to J5) to Raspberry Pi® 5 RTC
<p>Supported Battery Types and Capacities</p> <ul style="list-style-type: none"> - Supports a wide range of different Chemistry and capacities batteries and Super Capacitor (LiPO/LiFePO4/Li-Ion/ Super Capacitor 4000F) - Support for Li-Ion 18650 low-cost batteries (from Electronic Cigarettes) with dedicated holder on top - Support for LiPO 18650 batteries with dedicated holder on top - Support for LiFePO4 18650 with dedicated holder on top 	<p>System Monitoring</p> <ul style="list-style-type: none"> - Status Monitoring – Powering Mode, Inbound current, Outbound current, Powering Voltage, Battery Voltage, Temperature (Raspberry Pi® 5 Core and M.2 – UPS & Power Management HAT), Timer State - Events Pi Log feature - System LEDs – ACT, M.2, USR, SYS, BAT, CHG, TMR, FAN, TMP, EPR (optionally selected can be mapped to User LEDs) - System Healthy, that informs user remotely if Raspberry Pi® 5 Core and M.2 – UPS & Power Management HAT are running properly, and system is power protected (based on various internal system triggers)
<p>User/Programmer Interface</p> <ul style="list-style-type: none"> - I²C Pico API Interface for Control and Monitoring, with over 50 programming registers - Support for 4 different users selectable I²C addresses sets: DEFAULT: 0x68, 0x69, 0x6A, 0x6B, 0x6C, 0x6D, 0x6E, 0x6F NO_RTC: 0x69, 0x6B ALTERNATE1: 0x58, 0x59, 0x5A, 0x5B, 0x5C, 0x5D, 0x5E, 0x5F ALTERNATE2: 0x48, 0x49, 0x4A, 0x4B, 0x4C, 0x4D, 0x4E, 0x4F 	<p>System Protection</p> <ul style="list-style-type: none"> - Optional Direct Raspberry Pi® 5 Button via Spring Loaded Pogo Pinpoint to J2 - Programmable Watch-Dog Hardware feature (Still Alive Timer) - PPTC 5A@5V fuse - ZVD circuit on all 5V GPIO connections - Micro-controller-based watchdog - Over-Temperature protection - Over-Current protection - PPTC, ESD, Reverse Polarity on EPR and PPoE powering inputs
<p>Embedded Peripherals and Interfaces</p> <ul style="list-style-type: none"> - 1 User Programmable button - externally accessed - 1 User Programmable LEDs (with mapping capability of the system behavior LEDs) - externally accessed - 12bit 200Ksps A/D with voltage follower pre scaled to 0-5V0 and 0-25V0 - externally accessed - Additional Backed up User Applications Powering Sources 3V3 and 5V0 - Additional RS232 3V3 for user applications like System Schedule - System File Safe Shutdown/Start-up button with additional cable connectivity to external button (similar/alternative to Raspberry Pi® 5 but with ultra-low current consumption) - Integrated Hardware Real Time Clock (RTC) with Battery Back-Up in addition and independent (synchronized) to Raspberry Pi® 5 RTC - Dedicated Cable for the Raspberry Pi® 5 RTC battery Supply 	<p>Embedded Sensors</p> <ul style="list-style-type: none"> - Inbound/Outbound High-side bi-directional hardware current/voltage sensing monitor with power calculation on 5V supply - onboard Voltage sensors: Battery Voltage Level Raspberry Pi GPIO 5V level Voltage EPR 5V0-32V0 level Voltage PPoE 5V0-32V0 level Voltage - onboard additional Temperature Sensor
<p>RTC Support and System Scheduler</p> <ul style="list-style-type: none"> - RTC Scheduler - Enhanced shutdown and start-up system based on various internal/external events: Time stamp, Cable Powering/Loss (UPS), Battery Level, Serial Port data, current etc. 	<p>Case Compatibility</p> <ul style="list-style-type: none"> - Dedicated Case Coming soon
<p>PCB Construction</p> <ul style="list-style-type: none"> - 2 oz copper PCB manufactured for proper high current supply and cooling - 6 mils track/6 mils gap technology 4 layers PCB - PCB Surface Finishing – Immersion Gold - Multi-layer Copper Thermal Pipes for increased System Thermal Response and better passive cooling 	<p>System Design</p> <ul style="list-style-type: none"> - Designed and Simulated with PDA Analyzer with one of the most advanced CAD/CAM Tools – Altium Designer - Design Based on Microchip 16-bit 16 MIPS micro controller - Industrial Originated
<p>M.2 (NGFF) M-Key Interface</p> <ul style="list-style-type: none"> - Supports 2230, 2242 and 2280 - Implemented SUSCLK 32.768 kHz - Independent 3A Power Supply with Battery Backup - Connectivity with Raspberry Pi® 5 via 16 pins FPC 	<p>System Indicators</p> <ul style="list-style-type: none"> - M.2 ACT LED - M.2 Powering LED - User LED - UPS System LED - Low Battery LED - Active Battery Charger LED - System Timer LED - Raspberry Pi 5 Fan Status LED - Raspberry Pi 5 Temperature LED - System EPR or PPoE Powering Status LED

